



Orientation Level Referees Course



Compiled and produced by Basketball New Zealand
under the review of the National Referees Officer

Orientation Level Referees Course

Progressive Record Card

Name: _____

Association: _____

Address: _____

_____ Telephone: _____

Course conducted by: _____

Week One: Introduction and Philosophy

Completed: _____ Date: __/__/__

Week Two: Basic Mechanics

Completed: _____ Date: __/__/__

Week Three: Basic Contact

Completed: _____ Date: __/__/__

Week Four: Basic Violations and Review

Completed: _____ Date: __/__/__

TABLE OF CONTENTS

How to use these notes—a guide to instructors.....	1
Session 1: introduction and philosophy.....	2
1 Role of the referee	2
2 Reasons for refereeing	2
3 Professionalism	2
3.1 Sacrifice.....	2
3.2 First impressions	2
3.3 Financial.....	3
3.4 Principles.....	3
4 How to prepare.....	3
4.1 Rules.....	3
4.2 Work.....	3
4.3 Style.....	3
4.4 General	4
5 Referee structure	4
6 How the game is scored	4
7 Review	4
Session 2: basic mechanics.....	5
1 Court.....	5
2 Game start – jump ball	5
2.1 Beginning of a game	5
2.2 Jump ball	5
2.3 Violations during a jump ball.....	5
3 Areas of responsibility.....	6
4 Mechanics.....	6
4.1 Purpose	6
4.2 Signals.....	6
4.3 Court positioning—general responsibilities.....	6
5 Official signals.....	8
6 Review	8
Session 3: basic contact.....	9
1 Court positioning – practical advice	9
1.1 Trail Referee.....	9
1.2 Lead Referee.....	10
2 Personal Foul.....	11
3 Technical Foul.....	11
4 Types of Contact	11
5 Act of Shooting.....	12

6	Free Throws.....	12
6.1	Duties of the Administering Referee	12
6.2	Duties of the Lead Referee	13
6.3	Technical Foul Administration	13
6.4	Unsportsmanlike/Bench Technical Foul Administration.....	13
7	Review	13
Session 4: basic violations and game management.....		14
1	Control of the Ball	14
1.1	Player Control.....	14
1.2	Team Control	14
1.3	Fumble	14
2	Travelling.....	15
2.1	Pivot Foot.....	15
2.2	Progressing with the Ball.....	15
2.3	Dribbling.....	15
3	Out of Bounds.....	16
4	Throw-in	16
5	Foul Shots	17
5.1	Shooter	17
5.2	Non –shooters.....	17
5.3	Penalty	17
6	3 Seconds.....	17
7	5 Seconds.....	18
8	8 Seconds.....	18
9	24 Seconds.....	18
10	Ball returned to the Back Court.....	19
11	Time Outs	19
11.1	Requests.....	19
12	Substitutions	20
12.1	Requests.....	20
13	State of the Ball	20
13.1	Ball becomes Live	20
13.2	Dead Ball.....	21
14	Injuries to Players.....	21
15	Local Rules.....	21
16	Tribunals	21
17	Course Review.....	22

How to use these notes - a guide to instructors

It is estimated that the Theory component of this course will be 4 x 2 hour sessions. The practical component has no specific timeframe as it is expected that each beginner will take a varying number of games to reach the necessary standard to obtain their C grade.

You will require:

- Whiteboard/chalkboard
- Appropriate markers
- Rule Book and Referees Manual (both FIBA)
- VHS video player
- Video "Officiating Made Easy"
- Booklet "How to Referee Basketball"
- Whistles and lanyards

Please refer to the Rule Book and Referees Manual as much as possible.

The notes are designed to give a logical sequence for learning.

Instructors should encourage interaction between students and instructors with as much practical experience as possible.

Before each session please make sure that you know and understand the notes to be delivered.

Make sure you keep accurate records of attendance during the course and sign the student's Progressive Record Card.

Session 1: introduction and philosophy

1 Role of the referee

- To see that the games are conducted within the spirit and intent of the rules.
- To see that no player or team gains an advantage outside the rules.
- The referee's presence should ensure that the best team on the day wins.

2 Reasons for refereeing

- Exercise
- Enjoyment
- Self Confidence
- Friendship/Camaraderie
- Financial/Pocket Money
- Maintain an involvement in the game
- Potential for advancement to higher level

3 Professionalism

3.1 Sacrifice

- Time away from:
family
friends
work
favourite pastimes
- Physically demanding
- Mentally demanding:
learning
watching
toughness

3.2 First impressions

- Only one opportunity
- How you are dressed
- How you present physically
- How you carry yourself (demeanour and body language)

3.3 Financial

- The moment you accept payment, no matter how small, **you become a professional.**

3.4 Principles

- You are the best of the best. Therefore, you must set the example for the others. Players and coaches will do what you allow them to do; therefore, do what you say you are going to do.

Remember: No-one is more important than the game.

4 How to prepare

4.1 Rules

- Learn them from beginning to end
- Learn the interpretation of the rules
- Learn the spirit of the rules
- Learn how to apply the rules

4.2 Work

- Train physically
- Train mentally – be ready to officiate all games, not just the important ones
- Train psychologically – a referee must be tough in tough situations

4.3 Style

- Your own – what suits you best
- Copy and observe other referees and incorporate the things you like and that suit your personality
- Your style changes over time with experience and maturity

4.4 General

- What is best for the game?
- How to react to difficult occasions (coach, player, fans)
- Advantage/disadvantage – how is this going to be called?
- Type of game, tempo, etc
- Type of call – a referee should call what affects the play
- Enjoyment – referees must enjoy what they are doing or they should give it away

5 Referee structure

- Use the attached chart (Appendix I) to explain how a referee is advanced to higher grades/levels and by whom.

6 How the game is scored

- Refer the students to the attached score sheets (Appendix II) and explain the various aspects:
 - Match details : Name of teams, grade, date
 - Personal details : Players names and numbers
 - Notation of scores : Personal and running scores
 - Notation of fouls : Personal and team tally
 - Notation of time outs
- Discuss the referees' responsibilities at half time and full time. Check that both the personal and running scores are the same and then sign off the sheet.

7 Review

- At this point, play the video "*Officiating Made Easy*" and finish the first session by handing out a Rule Book and the booklet "*How to Referee Basketball*".
- Encourage the students to read the booklet before the next session and to start reading the Rule Book – say, two rules per night. Get them to save up their questions about rules, etc, for the session next week.

end of first session

Session 2: basic mechanics

1 Court

Refer the students to the attached court diagrams (Appendix III) and explain the following:

- Court dimensions
- Boundary lines
- Centre circle – other circles
- Restricted area – free throw lanes

2 Game start – jump ball

2.1 Beginning of a game

- A jump ball starts all games.

2.2 Jump ball

- Toss between two opposing players
- Position of jumping players
- Height of toss
- Each jumper may have two taps and then the ball must be touched by one of the eight non-jumpers, the floor, referee, basket or backboard

2.3 Violations during a jump ball

- Jumper leaves jumping position before the ball is tapped
- Jumper tapping the ball before it reaches its highest point
- Contact other than a tap (punch, cradle, forearm, etc)
- Jumper tapping the tossed ball more than twice
- Non jumper enters circle before ball is tapped
- Non jumper entwining legs with opponent

Notes:

- Any bad toss should be retaken and all jump ball violations should be called immediately.
- The penalty for a violation is the ball awarded to the opponent at the nearest sideline for a throw-in.

3 Areas of responsibility

- Refer to the attached diagram titled “Areas of Responsibility for Both Officials” (Appendix IV) and discuss those responsibilities.

4 Mechanics

4.1 Purpose

- Mechanics have been designed to help with the efficient operation of the game, provide proper coverage of play situations and effect communication and administration of the game. Mechanics also establish ideal teamwork and understanding between officials.

4.2 Signals

- Very important – One must know and practise the exact signals that are in the FIBA Rule Book.
- Impression – If one communicates properly and with confidence, that feeling is contagious. Players, coaches and spectators have the right to know what is happening or has happened.
- Sell the call – Correct signals will help the official in difficult situations.
- Communication – Signals as in the FIBA Rule Book are the official's way of communicating. If done properly, it helps to prevent problems.
- Practice – Like everything else, to be done properly signals must be practised. Signalling in front of a mirror helps.
 - Count: 3, 5 and 8 seconds. Practise counting in your head as it is very important. It would be unfair for a team pressing if the count were slow or for the offence if the count were too fast.
 - Tossing the ball: Practise, either one or two hands, so that it is higher than the players can jump.
Remember: It is better to toss the ball too high than too low.
 - Handling the ball: Out of bounds, free throws, etc, are only small things but must be done correctly.

4.3 Court positioning – general responsibilities

- Explain the Lead and Trail positions and refer to the attached diagram regarding the “boxing-in principle” (Appendix V). Also refer to the positioning on the jump ball and which referees go to which positions.
- **It is important to remember that there are no magic spots on the court.**

4.3.1 Lead Referee

- Do not look up
- Open hips to the play
- Move continuously
- Anticipate ball to defensive player relationship
- Back away from the baseline for a wider view
- Look away from the ball if it is **not** in your area
- Look for spaces between players. No space could be a foul

4.3.2 Trail Referee

- Move continuously.
- Look away from the ball if it is not in your area.
- If the ball penetrates (goes below the foul line extended) on a pass, dribble or shot, the trail referee **must penetrate** to at least the foul line extended to help partner with calls under the basket. Most of the contact in the game occurs in the restricted area (key).
- Look for spaces between players. No space could be a foul.
- Anticipate ball to defensive player responsibility.
- **Do not** back away when offensive team shoots. Penetrate and help partner.

- Anticipate the fast break by reacting quickly **after** the team on defence secures the ball.
- If caught behind the play on a fast break, hook in behind the players for a better angle.

4.3.3 Both Referees

- **Do not** focus on the ball if it is not in your area of responsibility.
- Keep all players boxed in between the referees as much as possible.
- Make eye contact as much as possible.
- Referee who makes the foul call should always go the trail position after signalling the call to the scorebench.

4.3.4 Referee not calling foul

- **Freeze:** Usually, if anything is going to happen, the time is immediately after a foul. **Do not** chase the ball (someone will get it sooner or later as the game cannot continue without it). Keep all players in view and wait until your partner has reported the foul to the bench, then proceed to position.

5 Official signals

- Refer to the attached diagrams (Appendix VI) detailing the correct signals.
- Explain and demonstrate the different signals emphasising the need for them to be easily understood by the scoretable, players, bench and spectators.
- Explain and demonstrate the correct foul and violation sequence at both the place where it occurs and the reporting to the scoretable.

6 Review

- Explain to the students that next week you will review the lead and trail responsibilities in more detail and that they will be asked to practise their signals in a group setting. Ask them to have a go at the signals they have been shown and hand out their whistles and lanyards. At this point, finish the session with the students having a go at blowing their whistle. Get them to blow it short and sharp and to get into the habit of letting the whistle fall from their mouth.

end of second session

Session 3: basic contact

Before commencing this section, get all the students to spread themselves out, put on their whistles, and practise their signals. Practise blowing the whistle and actually calling a violation or foul. You decide what the call should be, then get them to signal the call to you (as if you were the bench). It is then up to you to help them to get the signal and sequence correct.

Spend about ten minutes on this activity.

1 Court positioning – practical advice

1.1 Trail Referee

- As the name suggests, stay behind the play, but not too far away. When the play is moving forward up the court, keep behind and to the left of the ball, about 2 metres away. This will help you maintain a wide angle on the play and improve your court coverage. Also move to look for the spaces between players. If you can see a space, then there is no decision to be made.
- You are responsible for the sideline to your left, centre line violations, and 8-second violations.
- Even if the ball is brought up the court on your far right, do not go beyond the split line (line between the two baskets) except in a double team situation or trap.
- You are primarily responsible for the flight of the ball on all shooting situations and therefore, the possibility of basket interference and goal tending. Watch the feet of the shooter in relation to a 3-point attempt, and remember that you will always confirm a successful attempt to the bench. Ensure that you closely observe the defensive player's actions and avoid taking a position directly behind the shooter.
- Once the ball has been released for a shot, penetrate towards the basket. Do not back away anticipating a quick counter-attack. You are primarily responsible for keeping the rebounding clean. Be aware of players coming over the back of opponents in order to obtain a rebound illegally.
- Whenever the ball is passed or released for a shot, observe the actions of the defensive player before looking at the ball.
- When your partner looks for assistance on an out-of-bounds call, be prepared to give it immediately, **if you know**. Give the direction of play to your partner or indicate that you do not know.
- Even in transition from trail to lead, do not turn your head away from the play. Keep your eyes focused on the play at all times.
- Referee the defensive player on all one-on-one situations when you are responsible for the on-ball coverage.

1.2 Lead Referee

- You should get down the court as quickly as possible and allow the play to come towards you. Always keep on the move. If you stand still you run a greater risk of missing the play because of players cutting across your angle of vision. Strive for the best possible position. Hustle to get in line

with the ball and always know where it is even when you are primarily watching play off the ball.

- You are responsible for the end line and the side line to your left. Be prepared to help with the 8-second violation.
- Be ready to assist your partner with the 3-point field goal attempt, particularly when the ball is in Area 4. Establish eye contact with your partner.
- As you referee “off the ball” when the ball is beyond the free throw line extended, pay particular attention to the post play and the amount of physical contact you will tolerate. Any rough play is your responsibility, and you should penalise it. Recognise whether or not the player is trying to move into a new position and is being prevented illegally by an opponent from doing so.
- Do not move onto the court to get closer to the play. Keep on the move with proper positioning. As the play comes towards you, strive to maintain a good visual angle. You should use the “button hole” principle if you cannot get in front of the play on a fast break.
- At the end of a period, do not indicate whether the field goal shall count or not. This is the primary responsibility of the trail referee.
- Do not penalise minor contact, especially when a player drives to the basket and scores and your call means cancelling the basket. Similarly do not call a foul because a defensive player puts on a theatrical display and falls to the floor. Call things that have a direct bearing on the play.
- When your partner looks for help on an out-of-bounds play, be prepared to give it immediately, **if you know**. Give the direction of play or indicate that you do not know.
- In the event of a pressing defence with three or more defensive players in the back court, you must assist your partner with the coverage of the play. In this situation, you will delay your progress up the court and help.
- Referee the defensive player in all one-on-one situations when you are responsible for the on ball coverage.

2 Personal Foul

There are three attributes that constitute a personal foul.

- *Player foul* – all personal fouls can only be called on the ten players actually on the court.
- *Contact involved* – all personal fouls must involve actual physical contact.
- *Opponents* – all personal fouls must involve contact between opponents.

Note: Personal fouls may occur during both live and dead ball periods.

3 Technical Foul

Technical fouls are all non-personal fouls (no contact) during playing time and all fouls (including contact) during intervals of play. There are two types of technical fouls.

- *Unsatisfactory conduct* – this involves conduct by a player, coach or bench personnel that includes swearing, disputing decisions, obscene or

demeaning gestures, leaving the coaches box, players illegally leaving the court or illegally coming onto the court during play.

- *Procedural infractions* – this involves procedural errors such as 6 players on the court, requesting a time out when none are left, substitution errors, etc.

Note: Make every effort to sort out these problems without calling a technical foul. Most of these errors are not intentional; therefore, only penalise the ones that you believe are deliberate.

Refer to Article 38 for a full list of the types of conduct that constitute a technical foul.

4 Types of Contact

Instructor should demonstrate the following personal fouls and discuss the type of contact that would result in a foul being called:

- Blocking
- Charging
- Hands/hand checking
- Holding
- Pushing
- Illegal screens – blocking off ball

Instructor should demonstrate and discuss the following situations in relation to calling a personal foul:

- Legal defensive stance/ Guarding position
- Legal position – Block/ Charge
- Principle of verticality
- Guarding a player without the ball
- Player in the air
- Post play

Instructor should discuss the following penalties and their relationship to specific types of fouls.

- Sideline
- Two or three shots
- Team control
- Technical Foul by Player – 2 + possession
- Unsportsmanlike – 2 + possession
- Disqualifying – 2 + possession
- Bench by Coach or Bench Personnel – 2 + possession

5 Act of Shooting

Instructor should demonstrate and discuss the following matters in relation to the shooting action:

- The gathering of the ball following a dribble and the start of the shot.
Note: There is no set time or distance involved, with limitations only being continuous motion and travel. If there is a pause or a second gather in the act, then the shot ends immediately.
- The gathering of the ball and the start of the shot from a non-dribbling position
- A tap for goal

Note: A player who taps the ball towards the goal from a jump ball shall not be considered to be in the act of shooting.

A dunk for goal

6 Free Throws

6.1 Duties of the Trail Referee

After returning from reporting the foul to the score table and allowing reasonable time for the players to take their positions, the Trail Referee shall:

- Check lanes spaces
- Back away and move to a position where the free throw line intersects the 3 point line and using your arms, hold up the number of free throws to be taken. This should be held at shoulder height.
- Check right side of lane and the shooter's feet for violations and fouls
- Observe whether the ball goes through the basket or misses the ring
- Signal point if free throw successful

6.2 Duties of the Lead Referee

- See that the players are lined up in the correct positions
- Inform players of the number of free throws
- Check score table for incoming substitutions or problems
- Bounce the ball to the shooter

Note: The Trail Referee does not handle the ball

- Take a position off the end line with one foot either side of the line extended from the free throw lane
- Observe the free throw lane opposite your side for violations and fouls

6.3 Technical Foul Administration

- Following the free throw, the Lead Referee bounces the ball to the Trail Referee who administers the throw-in from the centre line

6.4 Unsportsmanlike/Bench Technical Foul Administration

- No players shall line up along the lanes
- Lead referee administers free throws at the free throw line
- Trail referee waits at the centre line for the completion of the shots then administers the throw-in from that spot

7 Review

Explain to the students that next week you will again ask them to practise their calls and signals in a group setting, and that during the week they should continue practising at home.

end of third session

Session 4: basic violations and game management

Before commencing this session repeat last week's exercise whereby you allow ten minutes for the students to practise their whistle blowing and the calling and signalling of fouls and violations.

1 Control of the Ball

Before discussing the various violations it is very important for the students to understand the difference between team control and player control. It forms the basis for a whole range of calls and penalties.

1.1 Player Control

A player is in control when they are holding or dribbling a live ball or in an out-of-bounds situation when the ball is at their disposal for a throw-in. Player control ends when the player is no longer holding or dribbling a live ball.

1.2 Team Control

A team is in control when a player of that team is in control and also when the ball is being passed between team mates. Team control ends when one of the following situations occurs:

- Opposition team gains team control
- The ball has left the hand on a try for goal
- The ball becomes dead (whistle is blown)

Note: Just because there is no player control does not mean that there is no team control.

1.3 Fumble

- A fumble is accidental loss of player control. There is no such thing as an intentional fumble.
- A player can fumble when trying to gain control or after gaining control of the ball.
- A fumble does not constitute a dribble.
- Players cannot violate (travel, double dribble, etc) if they do not have control of the ball.

2 Travelling

2.1 Pivot Foot

A pivot takes place when a player, who is holding the ball, steps in any direction with the same foot while the other foot is kept at its point of contact with the floor. Instructor should demonstrate the pivot foot when the following occurs.

- Receiving the ball with both feet on the floor
- Receiving the ball with one foot on the floor
- Receiving the ball with both feet off the floor

2.2 Progressing with the Ball

Instructor should demonstrate the following:

- A legal stop
- The first count
- The second count
- The pivot movement after a jump stop
- The pivot movement after a stride stop
- The allowable lifting of the pivot foot

2.3 Dribbling

Instructor should demonstrate the following.

- A legal dribble
- An illegal dribble
- When does a dribble begin?
 - player must have control
 - dribble can begin with a throw, tap or bounce
 - ball must contact the floor
 - player must touch it again before it touches another player
- When does a dribble end?
 - when the ball comes to rest in one or both hands
 - when the dribbler contacts the ball during a dribble with both hands simultaneously

Note: Any number of steps may be taken during a bounce or single dribble.

- What a player can do after a legal dribble:
 - shoot for goal
 - pass
- What a player cannot do after a legal dribble
- Dribbles are not:
 - successive shots
 - fumble and regaining of possession
 - tapping it from the control of another player
 - blocking a pass and recovering the ball
 - tossing the ball from hand to hand

3 Out of Bounds

- A player is out of bounds when the player touches a sideline, end line, or the floor or any object (including a non-player) beyond those lines.
- The ball is out of bounds when the ball touches a sideline, end line or the floor or any object (including a non-player) beyond those lines.
- If a player touches a live ball while they are out of bounds, they immediately cause the ball to go out of bounds.
- If a loose ball goes out of bounds, it is caused to go out of bounds by the last player to have touched it.

4 Throw-in

The following are throw-in violations:

- 5-second time limit to release the ball
- Failure to cause the ball to be touched by a player on the court
- Ball cannot be handed to a player on the court; it must be thrown or tossed
- Movement limitations at the throw-in spot:
 - one normal lateral step along the side line from the place designated by the referee before releasing the ball
 - laterally means along the side line; therefore, a player is permitted to move back as far as they like
 - approximately one metre in total distance covered, not one normal step laterally plus another normal step laterally back to the original point. A player could possibly take two or three very small steps as long as the total distance covered is approximately 1 metre

5 Foul Shots

There are two types of violations. Those by the shooter and ones by the non-shooters.

5.1 Shooter

- Taking more than 5 seconds to shoot the ball
- Touching the free throw line before the ball touches the ring
- Entering the restricted area before the ball touches the ring
- Missing the ring

Note: If the shooter's attempt is successful, or if the shooter violates, ignore all other violations.

5.2 Non – shooters

- Players occupying the wrong lane positions
- Moving from their established positions by the players in the lane spaces prior to the ball leaving the hand of the shooter
- Moving inside the three point line and the foul line extended by the players not in the lane spaces prior to the ball touching the ring
- Disconcertion
- On a free throw other than the last one, touching the ball while it is on, or bouncing above, the ring

5.3 Penalty

- Violation by opponent of free thrower is a substitute free throw
- Violation by the shooter or team mate on final unsuccessful free throw is a ball awarded to their opponents at the free throw line extended
- A double violation by both teams on a final missed free throw is a jump ball situation with possession going to the team that has the directional arrow.

6 3 Seconds

It is a violation for any offensive player to stay in the restricted area for more than 3 seconds. The count starts once a player on the court has player control in the front court and ends when the player's team no longer has team control.

Notes: It is not automatically a violation if a player stays in the restricted area for more than 3 seconds; advantage/disadvantage needs to be taken into account.

- The count is suspended if the player receives the ball inside the restricted area before 3 seconds and begins a try for goal.
- The violation is not for 3 seconds but for more than 3 seconds.

7 5 Seconds

It is a violation to hold the ball for 5 seconds either in the court or for a throw-in from out of bounds. The following criteria are needed for a violation to be called on the player who is in the court.

- The player must be holding a live ball.
- The defender must be making an active attempt to gain the ball or to aggressively guard.
- The defender must be within touching distance of the player with the ball.
- The only criterion for a violation to be called on the throw-in from out of bounds is that the 5 seconds has elapsed.

Note: The violation is for 5 seconds, not more than 5 seconds.

8 8 Seconds

It is a violation for the offensive team to take more than 8 seconds to progress the ball into their front court. The following criteria are needed for an 8 second violation to be called.

- The offensive team must have team control
- The time needs to be continuous except in the following circumstances when the offensive team is to receive the ball from out of bounds.
 - A ball having gone out of bounds
 - A player of the same team having been injured
 - A jump ball situation
 - A double foul
 - A cancellation of equal penalties against both teams
- The ball does not cross the centre line before 8 seconds has elapsed

9 24 Seconds

It is a violation if the offensive team does not shoot the ball, and touch the ring, within 24 seconds.

10 Ball returned to the Back Court

It is a violation if the offensive team, once it has progressed the ball to its front court, returns the ball to its back court. The following criteria are needed for a back court violation to be called:

- Team control must first have been established in the front court
- The ball returns to the back court
- The ball is last touched in the front court by an offensive player
- The ball is first touched in the back court by an offensive player

Note: All the above conditions must occur to be a violation. If one is missing, then it cannot be a violation.

The following are legal return of the ball to the back court:

- After a technical foul, the offensive team may pass the ball into its back court from the throw-in spot
- After an unsportsmanlike foul or bench technical foul, the offensive team may pass the ball into its back court from the throw-in spot

11 Time Outs

11.1 Requests

A request for a charged time out must come from the coach, assistant coach or playing coach.

11.1.1 *When Allowed*

- The clock is stopped and the ball is dead.
- After the opposition has scored a field goal.
- After a successful last free throw.
- Time outs will not be granted between free throws.

Note: A coach may withdraw a request up until the sounding of the horn to signal the request to the referees.

11.1.2 *Number and Limits*

- The number of time outs varies depending on each local Association's rules as well as the various League rules. Familiarise yourself with the local rules regarding time outs
- Time outs last 60 seconds, but the players must come back from the time out after 50 seconds so that the game can re-start after 60 seconds has elapsed
- Time outs may be taken one after the other
- After the last time out is taken in a half, the referees shall inform the coach that there are no more time outs left
- Unused time outs may not be carried over into the following periods; however, this rule also varies according to local playing conditions

12 Substitutions

12.1 Requests

A request for a substitution must come from the player who is substituting into the game. The player reports to the scoretable then waits for the next available opportunity to enter the game. At local Association level, this is not strictly enforced as coaches, assistant coaches and playing coaches can generally request substitutions. Check the local playing conditions regarding substitutions.

12.1.1 *When allowed*

- The clock is stopped and the ball is dead
- Before the ball goes into play again
- Substitutions will not be granted between free throws
- After the opposition has scored a field goal in the last two minutes of the final quarter/second half

12.1.2 *Limits*

- If a foul or violation is called then both teams may substitute
- Both teams may substitute when there is a stoppage in play initiated by the referees.
- A player taking free throws may not be substituted except in case of an injury.
- If a team wishes to substitute after a successful last free throw, the request can be made up until the ball is at the disposal of the player throwing the ball in from out of bounds on the base line. **EXCEPTION:** If the free thrower is a substitute for an injured player then they must remain in the game until the next stop clock period.

13 State of the Ball

13.1 Ball becomes Live

Refer to Article 10.2 in the Rule Book and discuss when the ball becomes live.

13.2 Dead Ball

Refer to Article 10.3 and 10.4 in the Rule Book and discuss when the ball is dead.

14 Injuries to Players

The referees may stop the game in case of injury to players.

If the ball is live when the injury occurs, the referees shall withhold their whistles until the play is completed, a shot for goal or the ball is lost by the team in control.

Note: The referees **MUST** suspend play if there is a danger to the injured player.

15 Local Rules

Explain that local rules can sometimes differ from the Rule Book. The main reason is generally related to time constraints. Each referee should acquaint themselves with the local playing conditions. The main areas that differ are:

- Length of game
- Number of time outs
- Intervals of play
- Stopping of the clock
- Substitutions
- Equipment eg. 24 second shot clock
- Uniforms
- Gender (eg. mixed)

16 Tribunals

If possible, get a member of the local tribunal to give a talk on this topic. However, if they are not available, cover the following items:

- Referees' responsibility to report
- How to go about making a report, including the filling out of the report form (example attached as Appendix VII). Items to bear in mind include the following:
 - Location – where the incident occurred on the floor
 - Preceding play – what was the lead up to the incident?
 - Players involved – you must know the numbers of the players and club
 - Details of incident – arm, open hand, fist, etc?
 - Where the ball was in relation to players – if ball was in area, where was it?
 - What happened to the player – injury, bleeding? Did they receive medical attention?
 - What did the players say? – record what was said
- Explain the various charges that can be laid. See the attached “Penalties for Non-Doping Offences” (Appendix VIII).
- Explain how a tribunal is conducted and what role the referees play.

17 Course Review

Review the course and answer any questions.

It is very important at this point that the students understand what is their next step. This course content was theory (except for the signalling practice) and was designed to prepare the students for when they go onto the court for the first time.

It will be extremely stressful the first few times on the court, so if we can help the students by placing them in the correct position and they feel comfortable with their signalling, then they can relax a little and start making some calls.

When they first go on the court it would be preferable that a senior referee stand alongside them and help with their positioning and calling. Once they feel more comfortable, the senior referee and the student will then operate as a normal two-person team with the senior referee providing assistance and feedback until the student is considered to have reached the C Grade level. The instructor who took the course will normally be the person who grades the student C Grade.

To attain their C Grade, the student will need to know the correct court positioning, communicate calls to the players and scoretable, and call the obvious fouls and violations.

end of final session

APPENDIX I

Structure of Referees in New Zealand

Structure of Referees in New Zealand

To standardise referee levels throughout Oceania, it has been recommended that the region adopt a standard system that all countries will use. The following system has been recommended and will be adopted by Basketball New Zealand.

Level 1

This level incorporates three internal levels that are all based at a local association level.

C Grade

Prospective referees participate in a Orientation Level Referee School that is theory based and deals mainly with positioning, signals and the main aspects of calling. The referees will be mainly juniors who currently play basketball and their main reasons for taking up officiating would be for continued involvement in their sport as well as a monetary return i.e. a part time job.

The course would run for 8 hours over say four sessions and on completion they would then be linked in with their local competition and begin refereeing with a senior domestic official. This official would provide a hands on teaching role with the view to progressing the trainee to the stage where they know the correct court positioning, signal clearly and make the obvious calls. At this stage the official would be graded as C grade and become a member of the local association.

B Grade

After one season of regular officiating, consistently honoring appointments and a general improvement in overall performance, then the official would be upgraded to B grade.

Level 1/A Grade

After twelve months of regular officiating, a B grade official can apply to attend a Level 1(A Grade) school. This school would be both a theory and practical course with on court assessment being conducted on games of senior domestic standard. To attain a Level 1 the official would need to pass a rules examination, have clear and accurate signals and call the game where accuracy, control and court mechanics are of a sufficient standard to comfortably officiate at senior local level.

At this point local referees may choose to remain at this level and only officiate in their local competitions but for those who wish to progress to the higher levels of basketball, the following levels are in place.

Level 2

All officials who wish to progress beyond local basketball will need to attend a Level 2 course. This will involve a more intensive on court assessment on games of a higher standard. Elements of the on court emphasis will be accuracy, advantage/disadvantage, control, man management, presence/body language and mechanics. To obtain a Level 2, the official would need to pass a rules examination, FIBA fitness test as well as a satisfactory on court assessment.

Once the Level 2 has been obtained the officials will be entitled to officiate at Premiership and National tournaments.

Level 3

Promotion to Level 3 will be based on performances at Premiership and National tournaments. Once Level 3 is obtained the officials will be entitled to officiate all basketball in New Zealand except the men's National League.

Level 4

Promotion to Level 4 will be based on performances in all the leagues other than the men's National League. Once Level 4 is obtained the officials will be entitled to officiate in the men's National League.

Level 5

This level is the FIBA officials. Beside international appointments, it is expected that some of these officials will officiate in the Australian NBL.

Note:

To maintain Levels 2, 3 & 4 all officials will need to annually pass a rules examination and fitness test as well as maintain their on court performance.

As this is a new requirement for most referees there will be a phase in period for passing of the fitness test for referees at Level 2, however the fitness test for the other levels will be commenced for the 2004 season. All referees at these levels will be sent the fitness test requirements and will have at least six months to reach the required fitness level.

APPENDIX II

Scoresheets



**FEDERATION INTERNATIONALE DE BASKETBALL
INTERNATIONAL BASKETBALL FEDERATION
SCORESHEET**

Team A Cartoons

Team B Actors

Competition Mixed Date 01/01/01 Time 20.00 Referee _____
 Game No. 1 Place HereVille Umpire Joe Blow Joe Schmoe

Team A Cartoons

Time-outs _____ Team fouls _____
 Period 1

1	2	3	4
---	---	---	---

 2

1	2	3	4
---	---	---	---

 Period 3

1	2	3	4
---	---	---	---

 4

1	2	3	4
---	---	---	---

 Extra periods _____

Licence no.	Players	No.	Player in	Fouls	1	2	3	4	5
	J. Hook	4							
	R. Roadrunner	5							
	M. Mouse	6							
	D. Duck	7							
	S. Sylvester	8							
	P. Precious	9							
	T. Tweetipe (c)	10							
	G. Goofy	11							
	S. Chicken-Little	12							
	W. E. Coyote	13							
	W. Disney	14							
	M. Blanc	15							

Coach A. Hitchcock _____
 Assistant Coach S. Spielberg _____

RUNNING SCORE											
A		B		A		B		A		B	
1	1			41	41			81	81		121
2	2			42	42			82	82		122
3	3			43	43			83	83		123
4	4			44	44			84	84		124
5	5			45	45			85	85		125
6	6			46	46			86	86		126
7	7			47	47			87	87		127
8	8			48	48			88	88		128
9	9			49	49			89	89		129
10	10			50	50			90	90		130
11	11			51	51			91	91		131
12	12			52	52			92	92		132
13	13			53	53			93	93		133
14	14			54	54			94	94		134
15	15			55	55			95	95		135
16	16			56	56			96	96		136
17	17			57	57			97	97		137
18	18			58	58			98	98		138
19	19			59	59			99	99		139
20	20			60	60			100	100		140
21	21			61	61			101	101		141
22	22			62	62			102	102		142
23	23			63	63			103	103		143
24	24			64	64			104	104		144
25	25			65	65			105	105		145
26	26			66	66			106	106		146
27	27			67	67			107	107		147
28	28			68	68			108	108		148
29	29			69	69			109	109		149
30	30			70	70			110	110		150
31	31			71	71			111	111		151
32	32			72	72			112	112		152
33	33			73	73			113	113		153
34	34			74	74			114	114		154
35	35			75	75			115	115		155
36	36			76	76			116	116		156
37	37			77	77			117	117		157
38	38			78	78			118	118		158
39	39			79	79			119	119		159
40	40			80	80			120	120		160

Team B Actors

Time-outs _____ Team fouls _____
 Period 1

1	2	3	4
---	---	---	---

 2

1	2	3	4
---	---	---	---

 Period 3

1	2	3	4
---	---	---	---

 4

1	2	3	4
---	---	---	---

 Extra periods _____

Licence no.	Players	No.	Player in	Fouls	1	2	3	4	5
	H. Simpson	4							
	P. Muldoon	5							
	P. Hankey	6							
	R. Burr	7							
	C. Grant	8							
	M. J. Fox (c)	9							
	J. Wayne	10							
	M. Rooney	11							
	G. Chapman	12							
	W. Peters	13							
	T. Cruise	14							
	M. Gibson	15							

Coach E. Degeneris _____
 Assistant Coach W. Goldberg _____

Scorekeeper _____
 Assistant scorekeeper _____
 Timekeeper _____
 24" operator _____

Scores Period 1 A _____ B _____
 Period 2 A _____ B _____
 Period 3 A _____ B _____
 Period 4 A _____ B _____
 Extra periods A _____ B _____

Referee _____
 Umpire _____
 Captain's signature in case of protest _____

Final Score Team A _____ Team B _____
 Name of winning team _____



FEDERATION INTERNATIONALE DE BASKETBALL
INTERNATIONAL BASKETBALL FEDERATION
SCORESHEET

Team A Cartoons

Team B Actors

Competition Mixed Date 01/01/01 Time 20.00 Referee Joe Blow
Game No. 1 Place HereVille Umpire Joe Schmoie

Team A <u>Cartoons</u>		Team fouls		
Time-outs		Period 1 <u>1 2 3 4</u> 2 <u>1 2 3 4</u>		
		Period 3 <u>1 2 3 4</u> 4 <u>1 2 3 4</u>		
Extra periods				
Licence no.	Players	No.	Player in	Fouls
			1 2 3 4 5	1 2 3 4 5
	J. Hook	4	P P P P P ₁	
	R. Roadrunner	5	P ₁	
	M. Mouse	6	P P ₂	
	D. Duck	7	P ₁ P ₂	
	S. Sylvester	8	P ₁	
	P. Precious	9		
	T. Tweetipe (c)	10	P	
	G. Goofy	11	P ₂ P ₂ P ₂	
	S. Chicken-Little	12	P	
	W. E. Coyote	13	P ₁ P ₂ P ₂	
	W. Disney	14	P ₁	
	M. Blanc	15	P ₁ P P	

Coach A. Hitchcock
Assistant Coach S. Spielberg

Team B <u>Actors</u>		Team fouls		
Time-outs		Period 1 <u>1 2 3 4</u> 2 <u>1 2 3 4</u>		
		Period 3 <u>1 2 3 4</u> 4 <u>1 2 3 4</u>		
Extra periods				
Licence no.	Players	No.	Player in	Fouls
			1 2 3 4 5	1 2 3 4 5
	H. Simpson	4	P ₂ P ₂ P ₂	
	P. Muldoon	5	P P P	
	P. Hankey	6	P P ₂ P	
	R. Burr	7	P ₁ P ₂ P ₂	
	C. Grant	8	P ₁ P ₂ P ₂ P ₂ P ₂	
	M. J. Fox (c)	9	P ₂ T ₂ D ₂ D D	
	J. Wayne	10	P	
	M. Rooney	11	P ₂ P ₂ P ₂	
	G. Chapman	12	P	
	W. Peters	13	P ₁ P ₂ P ₂	
	T. Cruise	14	P ₁	
	M. Gibson	15	P ₁ P P	

Coach E. Degeneris
Assistant Coach W. Goldberg

Scorekeeper _____
Assistant scorekeeper _____
Timekeeper _____
24" operator _____

Referee Joe Blow
Umpire Joe Schmoie

Captain's signature in case of protest _____

RUNNING SCORE															
A		B		A		B		A		B		A		B	
11	1	1	6	41	7	0	81	81	121	121					
11	2	2	9	42	42	7	82	82	122	122					
13	3	3	13	43	43	7	83	83	123	123					
7	4	4	9	13	44		84	84	124	124					
7	5			45	45	9	85	85	125	125					
6	6	6	13	46	46		86	86	126	126					
11	7	7	4	47	47	6	87	87	127	127					
8	8		13	48	48		88	88	128	128					
4	8	8	6	49	49	6	89	89	129	129					
10	10		13	50	50	6	90	90	130	130					
7	11	11	4	51	51	6	91	91	131	131					
7	12		5	52	52	9	92	92	132	132					
13	13		8	53	53	9	93	93	133	133					
7	14	(14)	5	54	54	10	94	94	134	134					
15	15		9	55	55		95	95	135	135					
7	16	16		56	56		96	96	136	136					
17	17		(17)	57	57	(9)	97	97	137	137					
5	18	18	(6)	13	58		98	98	138	138					
13	19		11	59	59		99	99	139	139					
13	20	13	11	60	(17)		100	100	140	140					
21	21			61	61		101	101	141	141					
7	22	22	9	5	62		102	102	142	142					
23	23		6	63	(6)		103	103	143	143					
7	24	24	9	6	64		104	104	144	144					
25	25		13	65	65		105	105	145	145					
8	26	26	5	66	66		106	106	146	146					
27	(27)	(5)	5	67	67		107	107	147	147					
11	28	28		68	68		108	108	148	148					
11	29	5	13	69	69		109	109	149	149					
30	30			70	70		110	110	150	150					
5	31	31	9	6	71		111	111	151	151					
32	32		11	72	72		112	112	152	152					
5	33	33	9	11	73		113	113	153	153					
4	34	34	9	5	74		114	114	154	154					
35	35		5	75	75		115	115	155	155					
8	36	36	9	76	76		116	116	156	156					
4	37	37	5	77	77		117	117	157	157					
6	38	38	6	5	78		118	118	158	158					
39	39		5	79	79		119	119	159	159					
40	40	7	5	80	80		120	120	160	160					

Scores Period 1 A 20 B 14
Period 2 A 39 B 27
Period 3 A 58 B 47
Period 4 A 82 B 63
Extra periods A _____ B _____

Final Score Team A 82 Team B 63

Name of winning team Cartoons

APPENDIX III

Court Diagrams and Movement on Jump Balls

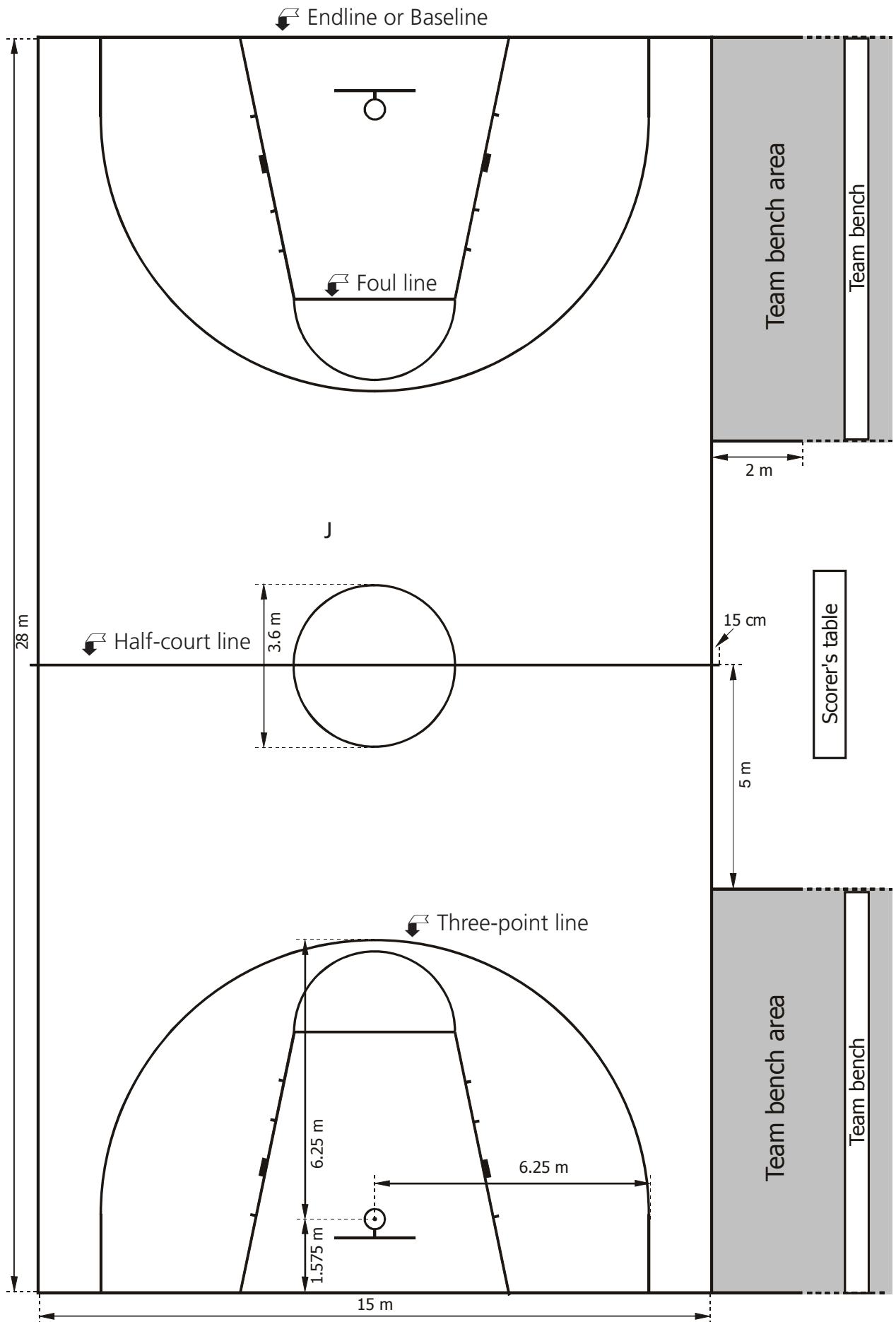

Restricted Area or Lane or Keyway

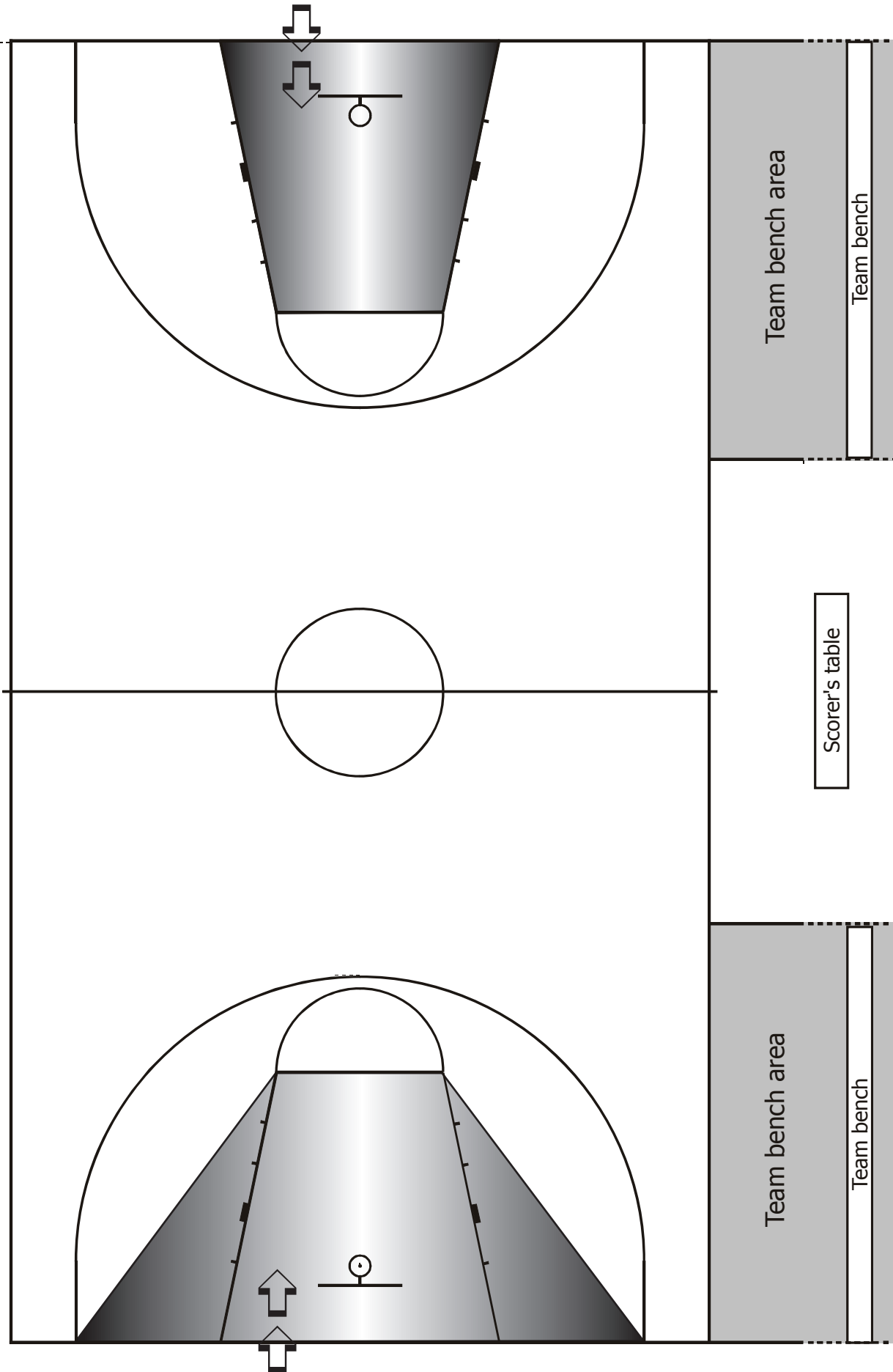

infracton Area for ball to come in from baseline

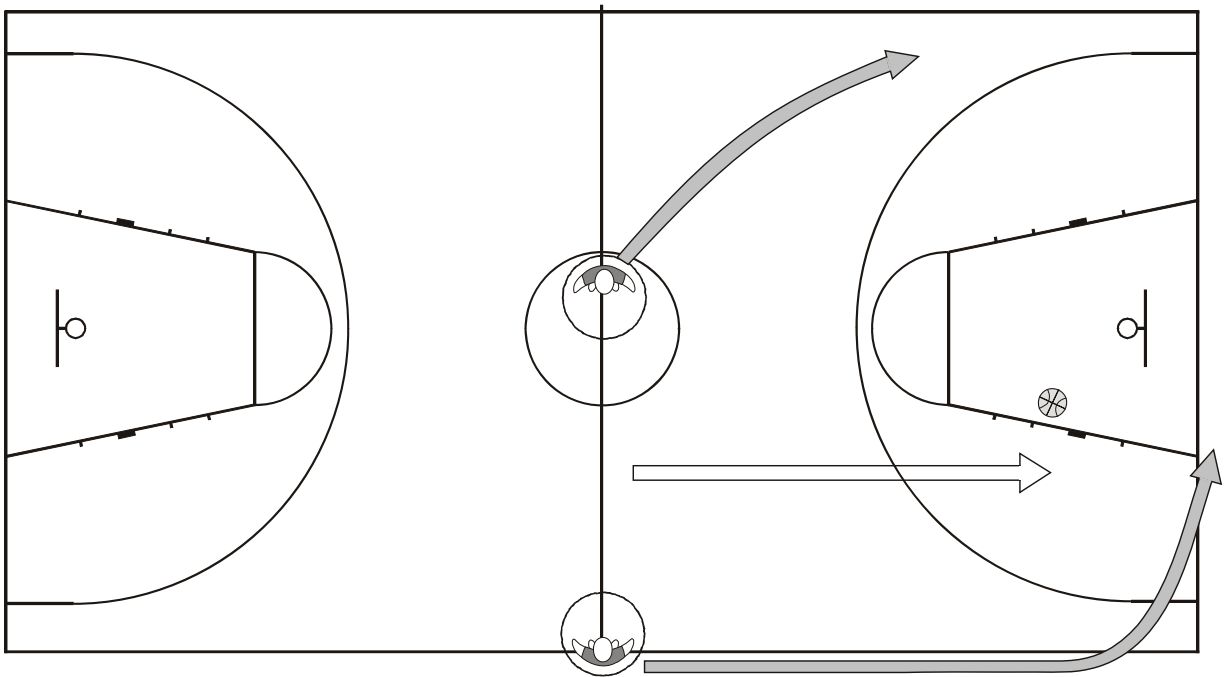
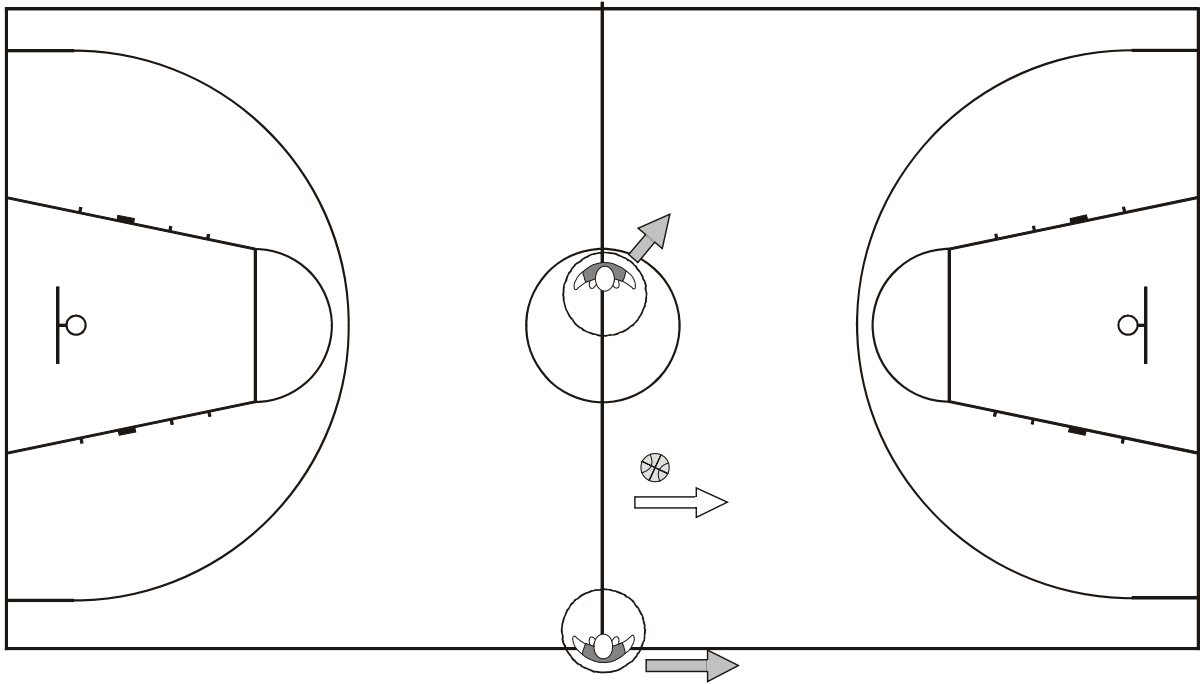

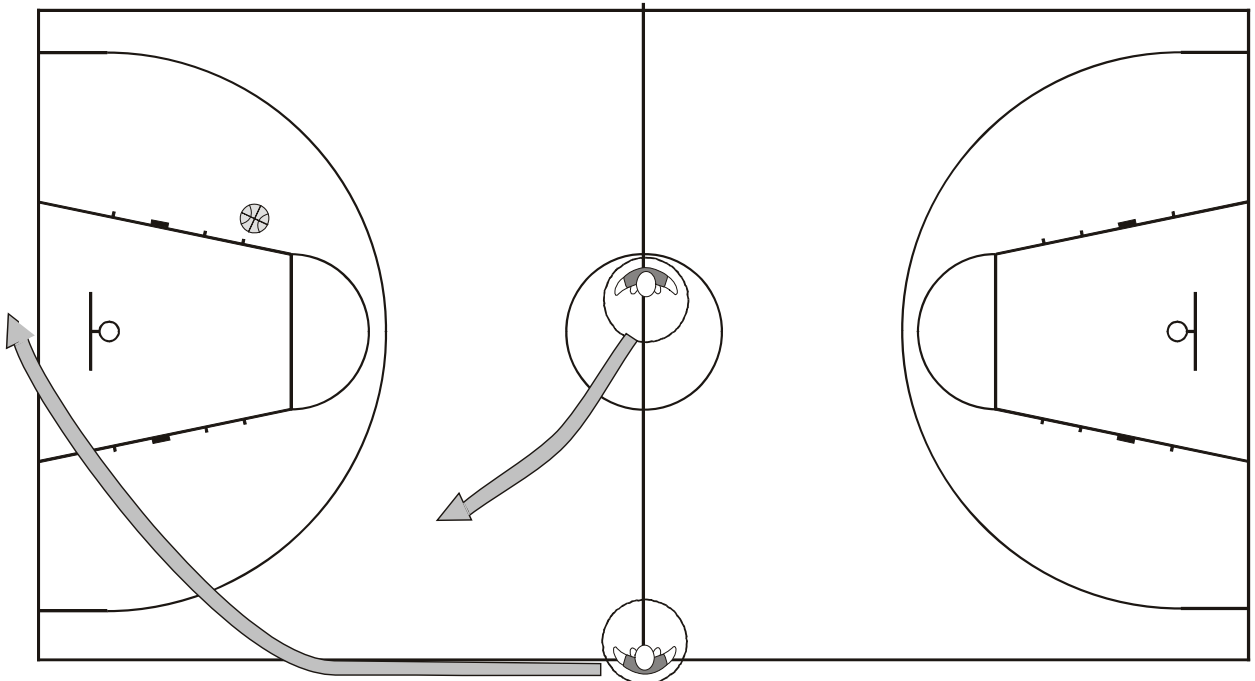
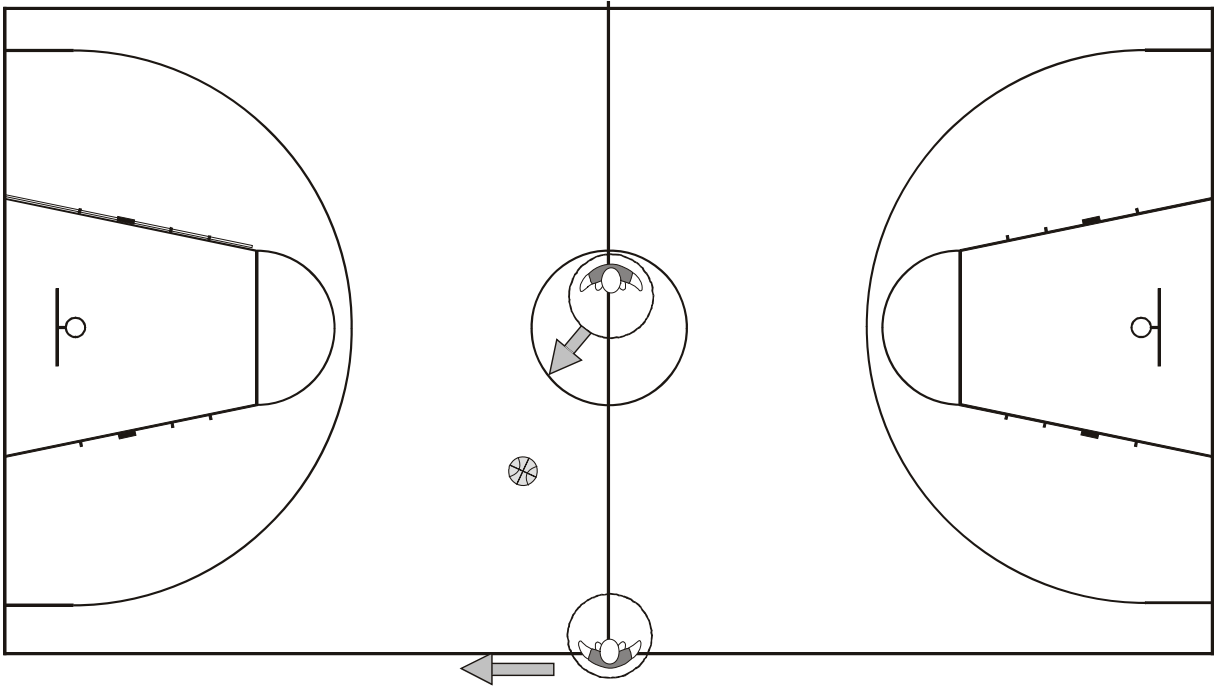

APPENDIX IV

Areas of Responsibility for Both Referees

 LEAD OFFICIAL:
Area 4 and share Area 5

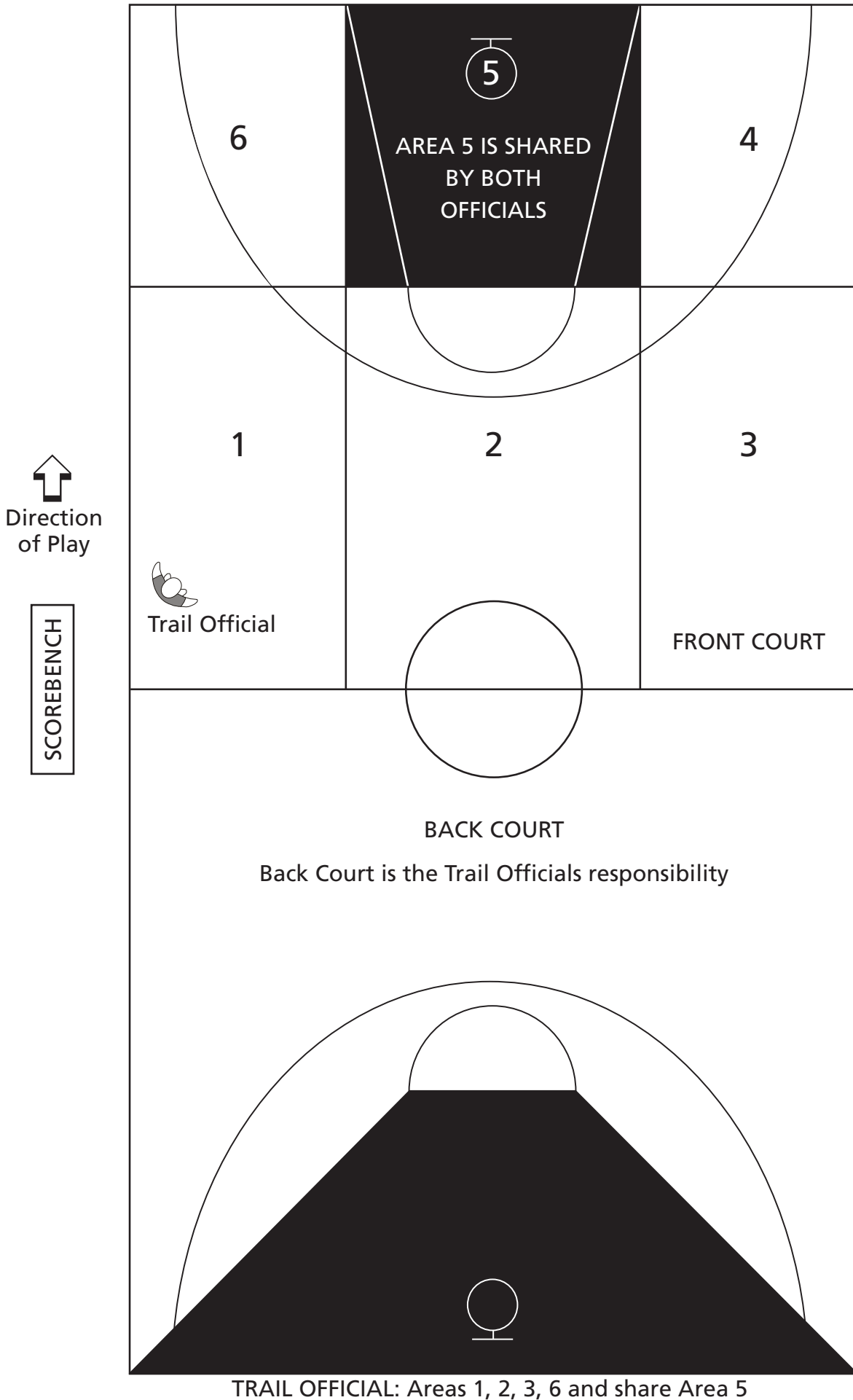

APPENDIX V

Lead and Trail Position re: “Boxing-in Principle”

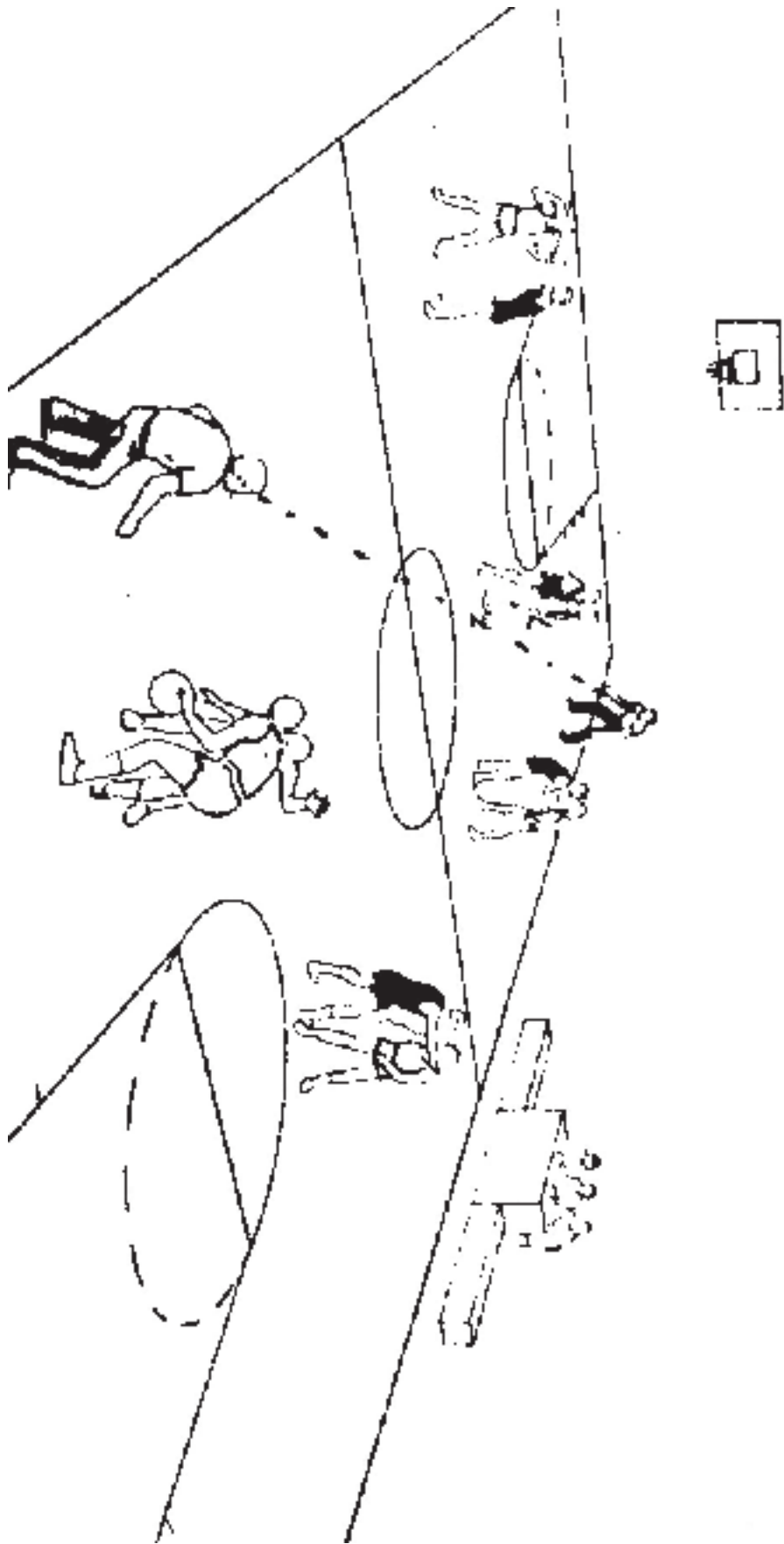

"Boxing-In" (or "Sandwich") principle.

APPENDIX VI





Official Signals

A - OFFICIALS' SIGNALS



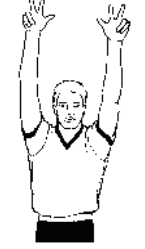

A.1 The hand signals illustrated in these rules are the only official signals. They must be used by all officials in all games.

A.2 It is important that the table officials are also familiar with these signals.

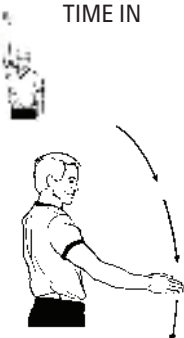

I. SCORING

<p>1 ONE POINT</p>  <p>One finger, 'flag' from wrist</p>	<p>2 TWO POINTS</p>  <p>Two fingers, 'flag' from wrist</p>	<p>3 THREE-POINTS ATTEMPT</p>  <p>Three fingers (extended)</p>	<p>4 THREE-POINTS SUCCESSFUL SHOT</p>  <p>Three fingers (extended) on each hand</p>	<p>5 CANCEL SCORE OR CANCEL PLAY</p>  <p>Scissor-like action with arms, once across chest</p>
---	---	---	---	--

II. CLOCK-RELATED





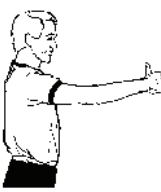
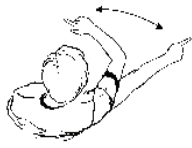

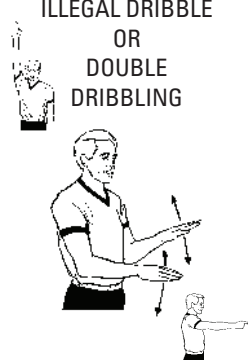

<p>6 STOP CLOCK (blowing whistle simultaneously) OR DO NOT START CLOCK</p>  <p>Open palm</p>	<p>7 STOP CLOCK FOR FOUL (blowing whistle simultaneously)</p>  <p>One clenched fist, other palm down pointing to offender's waist</p>	<p>8 TIME IN</p>  <p>Chop with hand</p>	<p>9 TWENTY-FOUR SECOND RESET</p>  <p>Rotate hand, index finger extended</p>
---	--	---	---

III. ADMINISTRATIVE

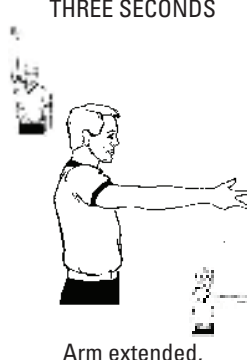
<p>10 SUBSTITUTION (blowing the whistle simultaneously)</p>  <p>Cross forearms</p>	<p>11 BECKONING-IN</p>  <p>Open palm, wave towards the body</p>	<p>12 CHARGED TIME-OUT (blowing whistle simultaneously)</p>  <p>Form T, index finger showing</p>	<p>13 COMMUNICATION BETWEEN OFFICIALS AND TABLE OFFICIALS</p>  <p>Thumb up</p>	<p>14 VISIBLE COUNT (Five and eight seconds)</p>  <p>Fingers showing counting</p>
---	--	---	--	--

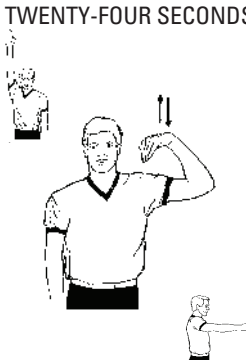
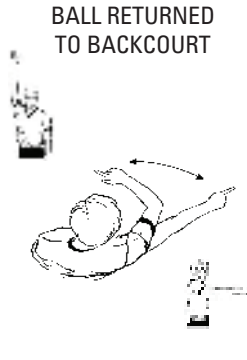













IV. TYPE OF VIOLATIONS

<p>15 TRAVELLING</p>  <p>Rotate fists</p>	<p>16 ILLEGAL DRIBBLE OR DOUBLE DRIBBLING</p>  <p>Patting motion</p>	<p>17 CARRYING THE BALL</p>  <p>Half rotation, forward direction</p>	<p>18 THREE SECONDS</p>  <p>Arm extended, show 3 fingers</p>	
<p>19 FIVE SECONDS</p>  <p>Show 5 fingers</p>	<p>20 EIGHT SECONDS</p>  <p>Show 8 fingers</p>	<p>21 TWENTY-FOUR SECONDS</p>  <p>Fingers touch shoulder</p>	<p>22 BALL RETURNED TO BACKCOURT</p>  <p>Wave arm, index finger pointing</p>	
<p>23 DELIBERATE FOOT BALL</p>  <p>Point finger to the foot</p>			<p>24 OUT-OF-BOUNDS AND/OR DIRECTION OF PLAY</p>  <p>Point finger parallel to sidelines</p>	<p>25 JUMP BALL SITUATION</p>  <p>Thumbs up followed by point finger in direction of possession arrow</p>







V. REPORTING A FOUL TO THE SCORER'S TABLE (3 Steps)

STEP 1 - NUMBER OF PLAYER



<p>26 No. 4</p> 	<p>27 No. 5</p> 	<p>28 No. 6</p> 	<p>29 No. 7</p> 
<p>30 No. 8</p> 	<p>31 No. 9</p> 	<p>32 No. 10</p> 	<p>33 No. 11</p> 
<p>34 No. 12</p> 	<p>35 No. 13</p> 	<p>36 No. 14</p> 	<p>37 No. 15</p> 



STEP 2 - TYPE OF FOUL

<p>38</p> <p>ILLEGAL USE OF HANDS</p>   <p>Strike wrist</p>	<p>39</p> <p>BLOCKING (offence or defence)</p>   <p>Both hands on hips</p>	<p>40</p> <p>EXCESSIVE SWINGING OF ELBOWS</p>   <p>Swing elbow backwards</p>	<p>41</p> <p>HOLDING</p>   <p>Grasp wrist downward</p>
<p>42</p> <p>PUSHING OR CHARGING WITHOUT THE BALL</p>   <p>Imitate push</p>	<p>43</p> <p>CHARGING WITH THE BALL</p>   <p>Clenched fist, strike open palm</p>	<p>44</p> <p>BY TEAM IN CONTROL OF THE BALL</p>   <p>Point clenched fist towards basket of offending team</p>	<p>45</p> <p>DOUBLE</p>   <p>Wave clenched fists</p>
<p>46</p> <p>TECHNICAL</p>  <p>Form T, palm showing</p>	<p>47</p> <p>UNSPORTSMANLIKE</p>  <p>Grasp wrist upward</p>	<p>48</p> <p>DISQUALIFYING</p>  <p>Clenched fists</p>	

STEP 3 - NUMBER OF FREE THROW(S) AWARDED

<p>49</p> <p>ONE FREE THROW</p>  <p>Hold up 1 finger</p>	<p>50</p> <p>TWO FREE THROWS</p>  <p>Hold up 2 fingers</p>	<p>51</p> <p>THREE FREE THROWS</p>  <p>Hold up 3 fingers</p>
---	---	--

OR
- DIRECTION OF PLAY

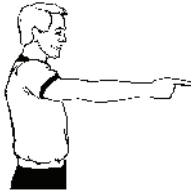
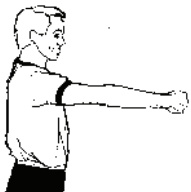
<p>52</p>  <p>Point finger, arm parallel to sidelines</p>	<p>53</p> <p>AFTER FOUL BY TEAM IN CONTROL OF THE BALL</p>  <p>Clenched fist, arm parallel to sidelines</p>
--	--



VI. FREE-THROW ADMINISTRATION (2 Steps)

STEP 1 - INSIDE THE RESTRICTED AREA

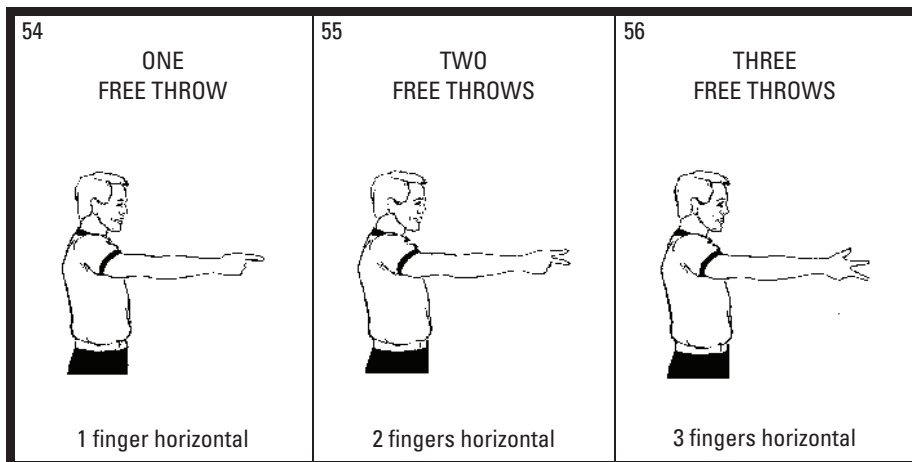

STEP 2 - OUTSIDE THE RESTRICTED AREA

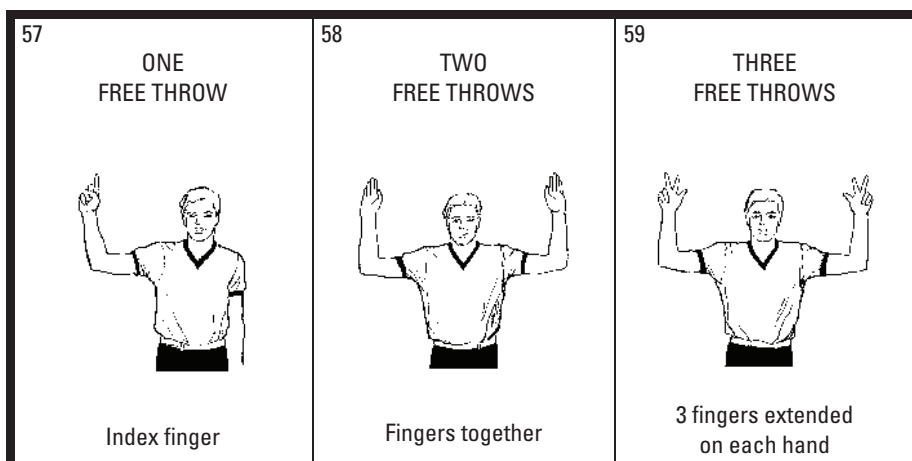

APPENDIX VII

Report Form

GAME INCIDENT REPORT

This form may be completed by Game Officials or any other witnesses

Date:	Venue:
-------	--------

Game:	vs
-------	----

Print Name (person compiling report):

Address:

Phone (Home):	(Day):
---------------	--------

Email:

Player(s) involved:			
Team	No.	Name	Penalty(s) Applied

Briefly describe the temperament of the game prior to the incident:

Describe the participants' actions which created the incident and during the incident:

Describe the actions which followed the incident (if any):

Signature: _____

Use reverse of form if necessary to write additional detail.

REPORT FORM

Coach _____

Player _____ No. ____ Team _____

Spectator _____

Other _____

Address _____

Date of Match _____ Time _____

Control Association _____

OFFENCE WITH WHICH PERSON IS CHARGED (Tick appropriate boxes)

PHYSICAL

- | | | |
|--|--|-----------------------------------|
| <input type="checkbox"/> TRIPPING | <input type="checkbox"/> ASSULT | <input type="checkbox"/> STRIKING |
| <input type="checkbox"/> ELBOWING | <input type="checkbox"/> ASSAULTING A REFEREE/ SCOREBENCH
or ASSOCIATION OFFICIAL | <input type="checkbox"/> KICKING |
| <input type="checkbox"/> FIGHTING | <input type="checkbox"/> TUNNELLING | <input type="checkbox"/> SPITTING |
| <input type="checkbox"/> OBSCENE GESTURE | | |
| <input type="checkbox"/> STRICKING OR KICKING A REFEREE/SCOREBENCH or ASSOCIATION OFFICIAL | | |

VERBAL

- OFFENSIVE LANGUAGE DISPUTING DECISION
- THREATENING A REFEREE/SCOREBENCH or ASSOCIATION OFFICIAL
- RACIAL VILIFICATION

OTHER

- UNSPORTSMANLIKE BEHAVIOUR
- PUTTING REFEREE/SCOREBENCH or ASSOCIATION OFFICIAL IN FEAR OF IMPENDING VIOLENCE
- PLAYING/COACHING/REFEREEING/SCOREBENCH DUTIES WHILST UNDER SUSPENSION

Referees Name _____

Umpire _____

Scorer _____

Timekeeper _____

Active/Non active _____

APPENDIX VII

Penalties for Non-Doping Offences

Penalties for Non-Doping Offences

The following are the recommended penalties for offences that occurred before, during or after a game.

	Suggested Minimum Suspension	Suggested Maximum Suspension
PLAYER TO PLAYER		
Kicking	6 weeks	52 weeks
Attempt to kick	2 weeks	10 weeks
Elbowing	6 weeks	40 weeks
Attempt to elbow	2 weeks	5 weeks
Fighting (including wrestling, several players involved)	5 weeks	52 weeks
Fighting (two players involved, including wrestling)	5 weeks	24 weeks
Striking with clenched fist	5 weeks	24 weeks
Attempt to strike with a clenched fist	2 weeks	6 weeks
Striking with open palm	3 weeks	20 weeks
Striking opponent with the ball or other objects	1 week	5 weeks
Deliberately tripping an opponent	2 weeks	7 weeks
Moving in under a player who is in the air	2 weeks	7 weeks
Playing unduly roughly	2 weeks	7 weeks
Using abusive or offence language or signs, threatening or obscene language	1 week	15 weeks
Adopting a threatening attitude	1 week	5 weeks
Participating in basketball while suspended	1 week	10 weeks
Unsportsmanlike conduct	1 week	5 weeks
MISCONDUCT TOWARDS OFFICIALS		
Unsportsmanlike conduct disputing decisions	1 week	24 weeks
Striking, kicking or elbowing	10 years	Life
Intentionally tripping	5 years	Life
Attempting to strike, kick, elbow or trip	4 years	Life
Adopting a threatening attitude	15 weeks	5 years
Adopting a fighting attitude	20 weeks	10 years
Using abusive, threatening or obscene language	5 weeks	21 weeks
Pushing with open palm or shoulder or hip	52 weeks	10 years
Striking with ball or other object	52 weeks	10 years
REFEREE, OFFICIALS AND COACH MISCONDUCT		
Unsporting conduct arguing with or between players, coaches or officials	1 week	6 weeks
Striking	10 years	Life
Intentionally tripping	5 years	Life
Attempting to strike, kick, elbow or trip	4 years	Life
Adopting a threatening attitude	15 weeks	5 years
Adopting a fighting attitude	20 weeks	10 years
Using abusive, threatening or obscene language	5 weeks	21 weeks
Pushing with open palm or shoulder or hip	52 weeks	10 years